

# FBV 440C

## FIRŠT BALL VALVES

4-way brass ball valves with Clip system

# FIRŠT®

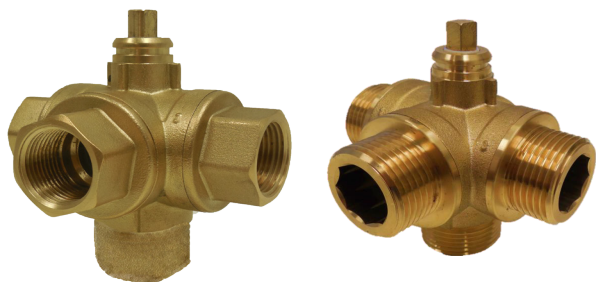

Valves are available in DN 15 – DN 25, with internal or external thread, and are rated PN 10.

- The FIRŠT ball valves FBV 440C are valves with three outlets and one inlet. They are used in systems with two heat sources, for the storage tank loading or storage tank heat stratification.
- Two types of connections are available: internal threads (FBV 441C), external threads (FBV 442C).

### OPERATION

The FIRŠT valves FBV 440C are designed: for bivalent system, where energy is taken from two heating units, for storage tank system for the loading or heat stratification and for diverting application with one inlet and three outlets.

Valves are suitable for long-lasting operation because of special sealing construction. Small rotation torque of the valve minimizes valve blocking.

Valves can be equipped with series 9000 or UNI (with modulating signal 0-10V) actuators which allow high regulating accuracy and easy installation with one-click CLIP system.

### MAINTENANCE

Valves require no maintenance. The installation of suitable strainer is recommended.

### TECHNICAL DATA

Nominal pressure:	PN 10
Medium:	drinking water, glycol < 50%, non aggressive liquids water quality as per VDI 2035
Media temperature:	min. +2°C max. +110°C
Max leakage:	rate A according to EN 12266-1:2003
Max. diff. pressure:	3 bar (recommended max. diff. pressure for low noise operation: 2 bar)
Connections:	Rp internal thread (EN 10226-1) G external thread (ISO 228-1)

### Material

Valve body:	Brass, CW617N
Ball:	Brass, CW617N
Seals:	PTFE, EPDM, FPM

**PED 97/ 23/ EC/ art 3.3**

### WORKING WAY

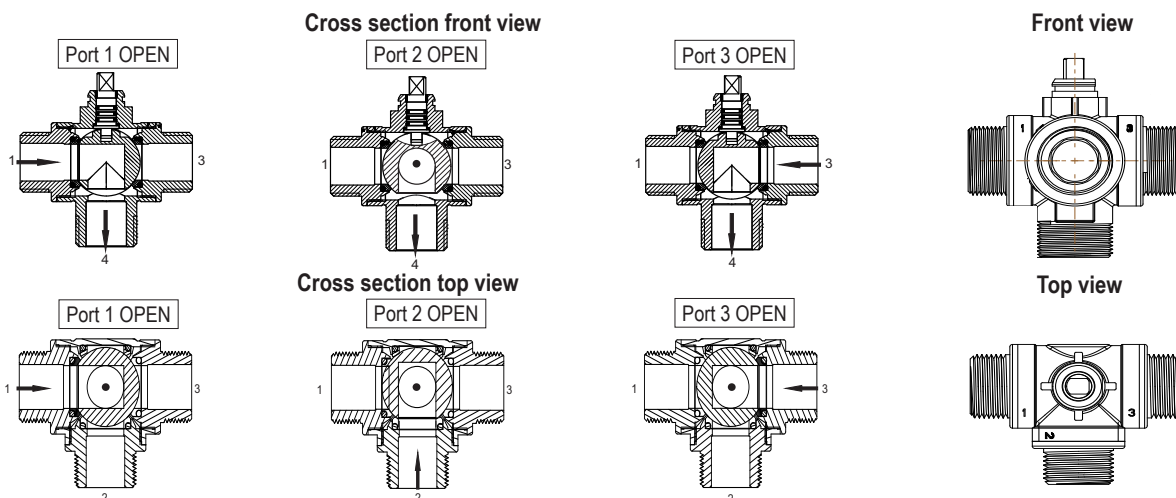

### SUITABLE ACTUATORS



- S9000 MOD X
- UNI MOD X

### CLIP SYSTEM

Compact design of the valve allows easy assembling and disassembling. Clip system allows easy installation of the actuator on the valve body with single click without any tools.



# FIRŠT®

**FIRŠT d.o.o.**  
Koroška cesta 56  
SI-3320 Velenje  
SLOVENIA

phone: +386 3 898 35 00  
fax: +386 3 898 35 35  
email: info@first.si  
web: www.first.si

**www.first.si**  
Let First be your first choice.



# FBV 440C

## FIRST BALL VALVES

4-way brass ball valves with Clip system

### FBV 441C

internal threads

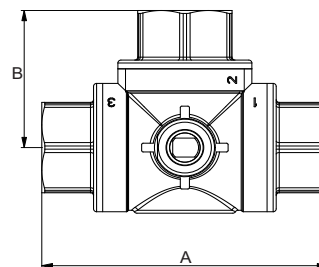
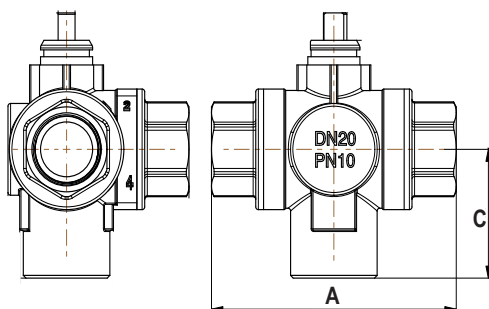
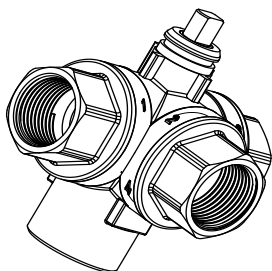

### FBV 442C

external threads

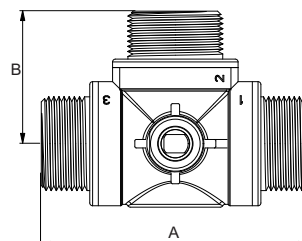
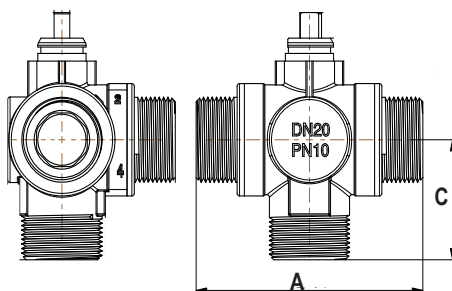
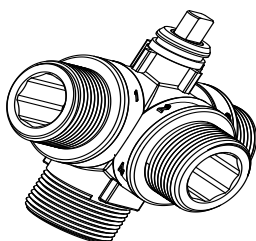

#### FBV 441C, internal threads

Code	Type	DN	Kvs	Connection	A	B	C	Weight [kg]	Price (€)
	*FBV 441C DN15 Rp 1/2"	15	6	Rp 1/2"	82	41	41	0,5	
41208	FBV 441C DN20 Rp 3/4"	20	10	Rp 3/4"	94	47	47	0,82	
	*FBV 441C DN25 Rp 1"	25	12	Rp 1"	106	53	53	1,3	

#### FBV 442C, external threads

Code	Type	DN	Kvs	Connection	A	B	C	Weight [kg]	Price (€)
	*FBV 442C DN15 G 3/4"	15	6	G 3/4"	82	41	41	0,55	
41208	FBV 442C DN20 G 1"	20	10	G 1"	94	47	47	0,88	
	*FBV 442C DN25 G 1 1/4"	25	12	G 1 1/4"	106	53	53	1,4	

\* Valves are available on special request

#### INSTALLATION EXAMPLES

##### 1. Storage tank loading

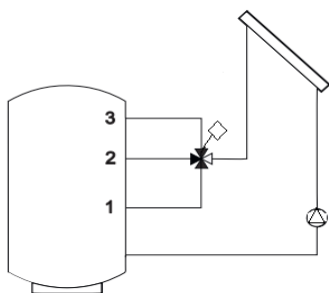

##### 2. Storage tank heat stratification

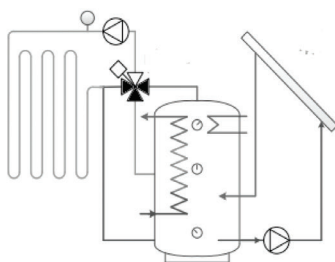

##### 3. Energy from two heating systems

